

# Adirondack Chair Plan

## SHOPPING LIST

- 3 – CULPEPER GROUND CONTACT 2×4 @ 8 feet long
- 1 – CULPEPER GROUND CONTACT 2×2 @ 6 feet long
- 4 – CULPEPER GROUND CONTACT 1×4 @ 8 feet long
- (30) 2 1/2" self-tapping wood screws
- (60) 2" self-tapping wood screws
- (20) 1 1/4" wood screws
- Exterior appropriate wood glue

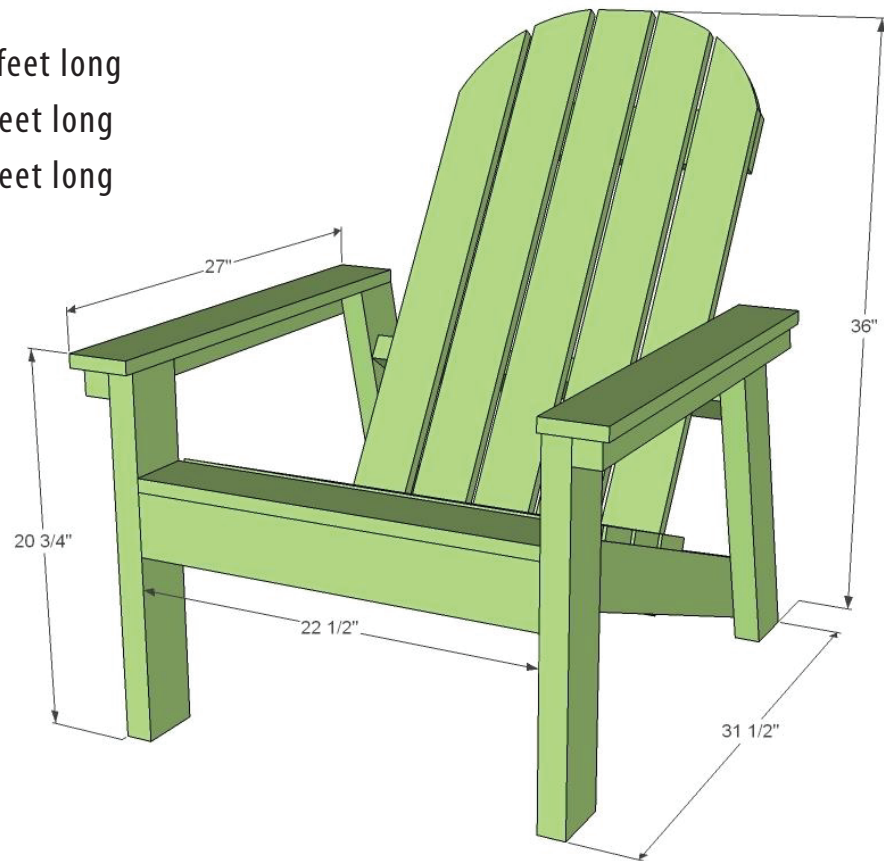

## CUT LIST

- |  |  |
|--|--|
| 2 - 2x4 @ 20 3/4" long with both ends cut parallel at 15 degrees off square (back legs)  | 2 - 2x4 @ 22 1/2" (front apron and back support) |
| 2 - 2x4 @ 20" (front legs)   | 5 - 1x4 @ 22 1/2" (seat slats)                   |
| 2 - 2x2 @ 26 1/2" long, longest point measurement, one end cut at 15 degrees off square (arm support)  | 5 - 1x4 @ 36" (back slats)                       |
| 2 - 2x4 @ 31 7/8" long, one end cut at 35 degrees off square to longest point, other end cut at 20 degrees off square to shortest point - see step 1 (stringers) | 1 - 1x4 @ 19 1/2" (back top support)             |
|  | 1 - 2x4 @ 19 1/2" (back base support)            |
|  | 2 - 1x4 @ 27" (arm rests)                        |

# STEP 1

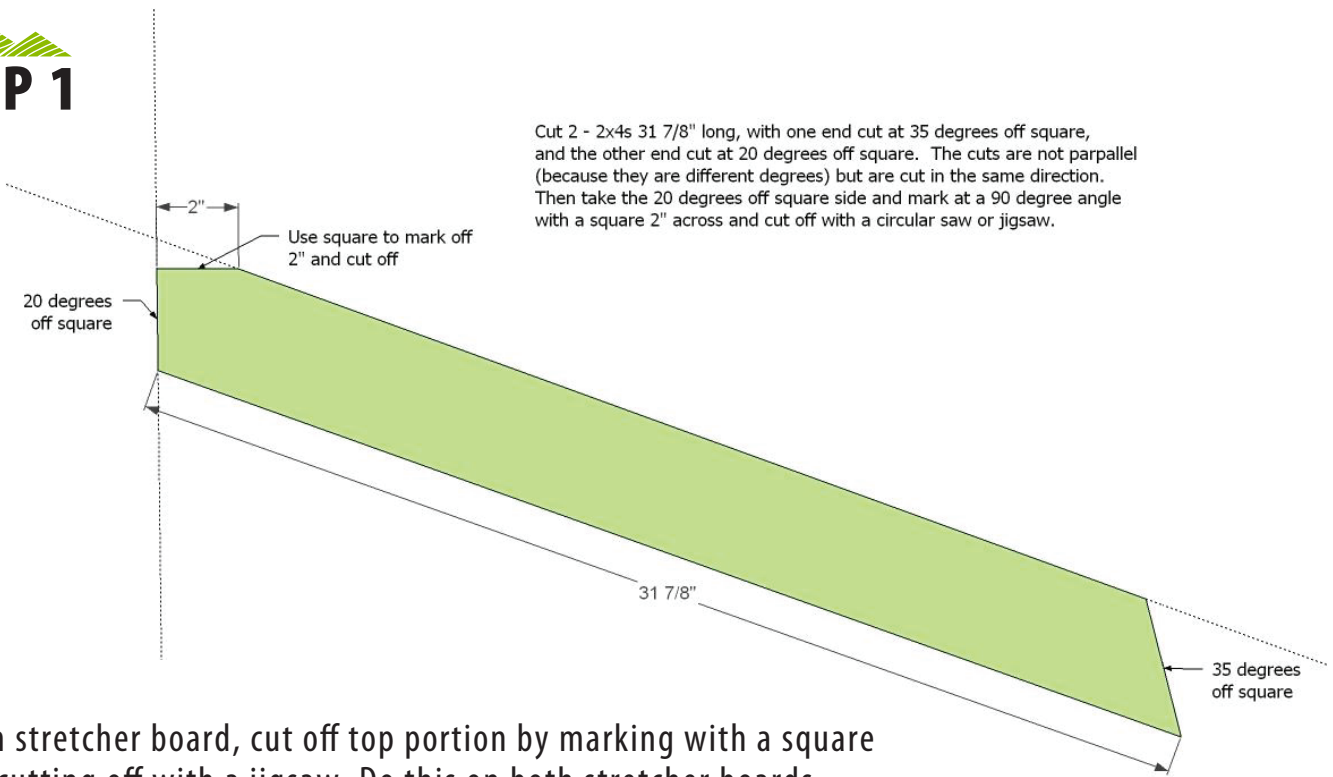

From stretcher board, cut off top portion by marking with a square and cutting off with a jigsaw. Do this on both stretcher boards.

# STEP 2

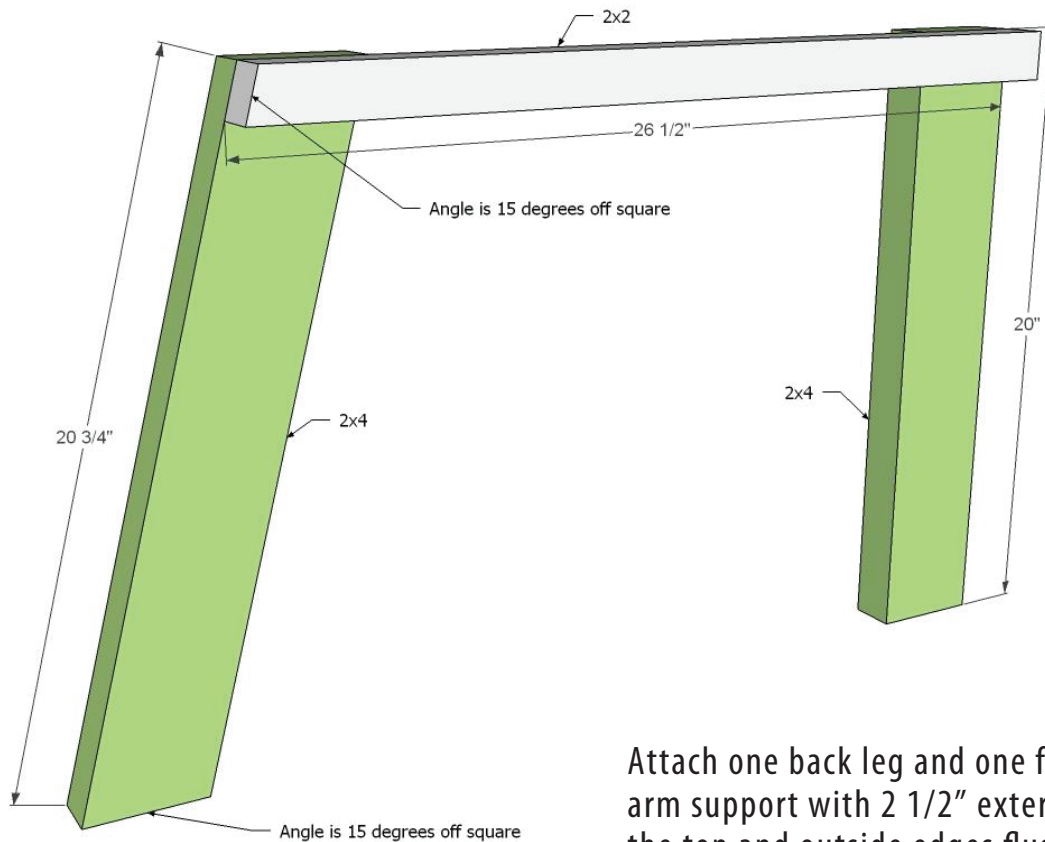

### STEP 3

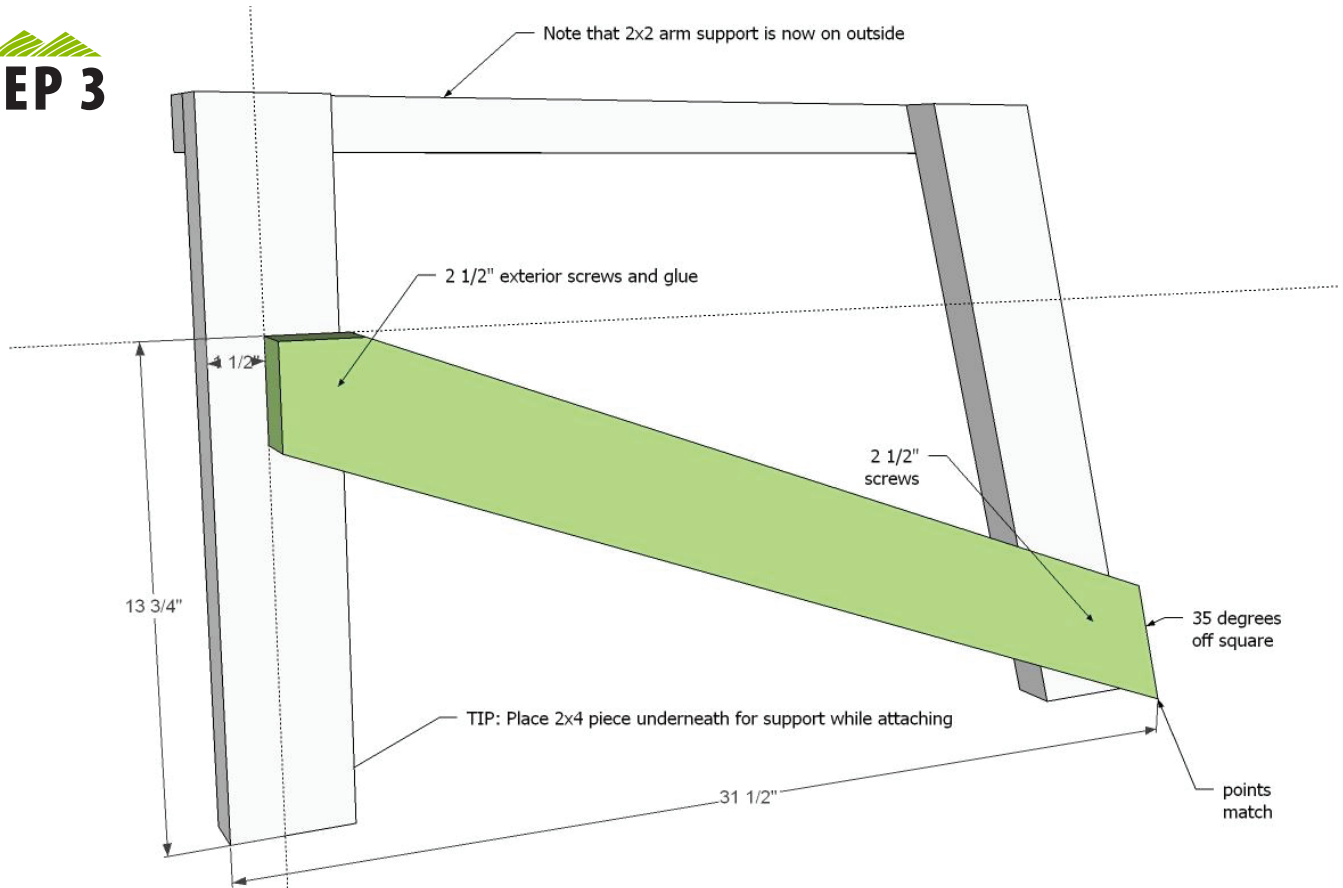

Mark front leg on inside with arm support on outside, as shown in diagram. Leave 1 1/2" space in front of stretcher. Attach stretcher to front and back legs with 2 1/2" exterior screws and glue.

### STEP 4

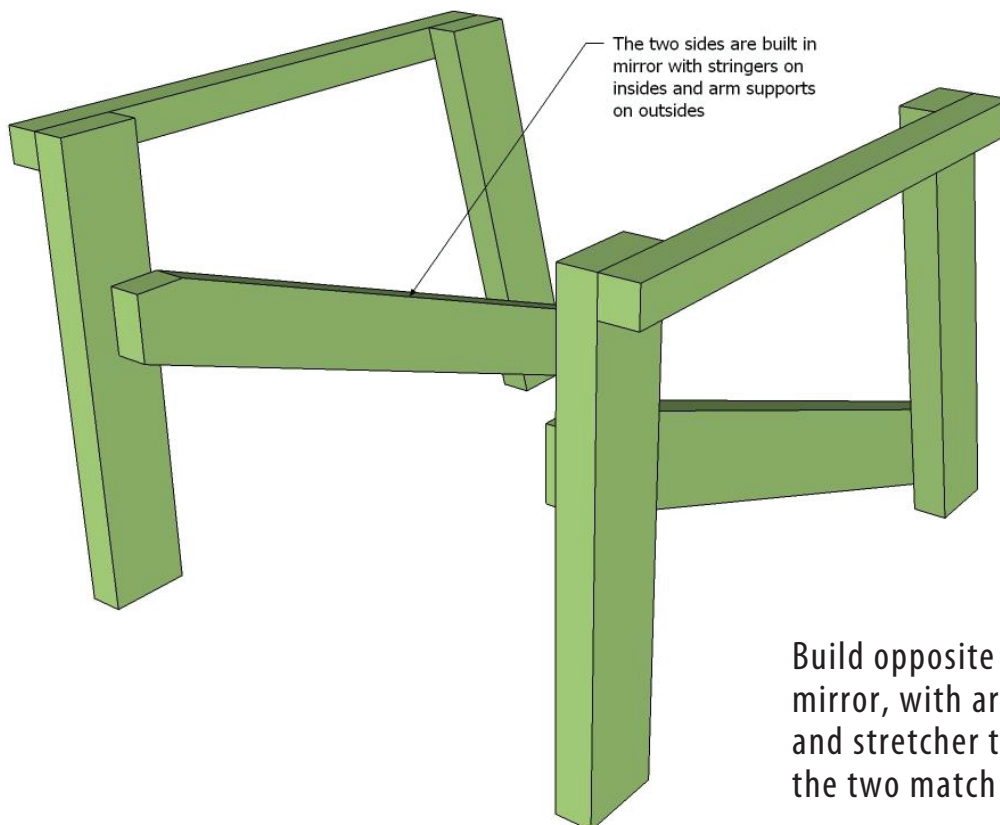

Build opposite side of chair in mirror, with arm supports to outside and stretcher to inside. Make sure the two match up.

## STEP 5

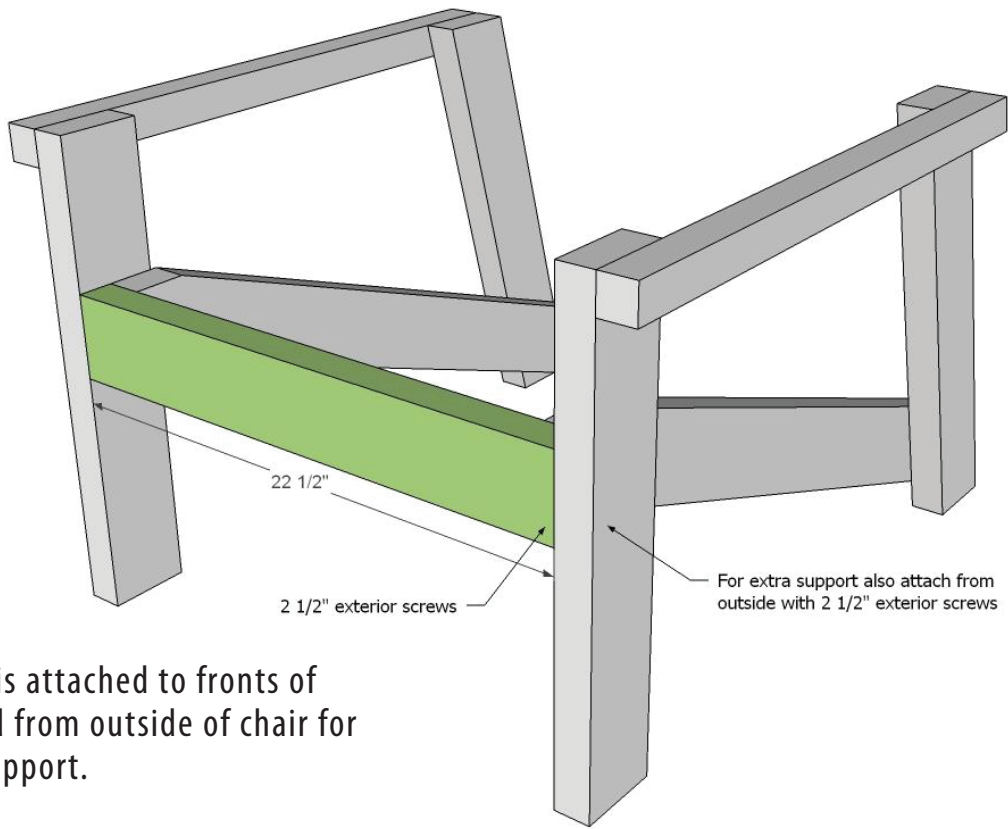

Front Apron is attached to fronts of stretcher and from outside of chair for additional support.

## STEP 6

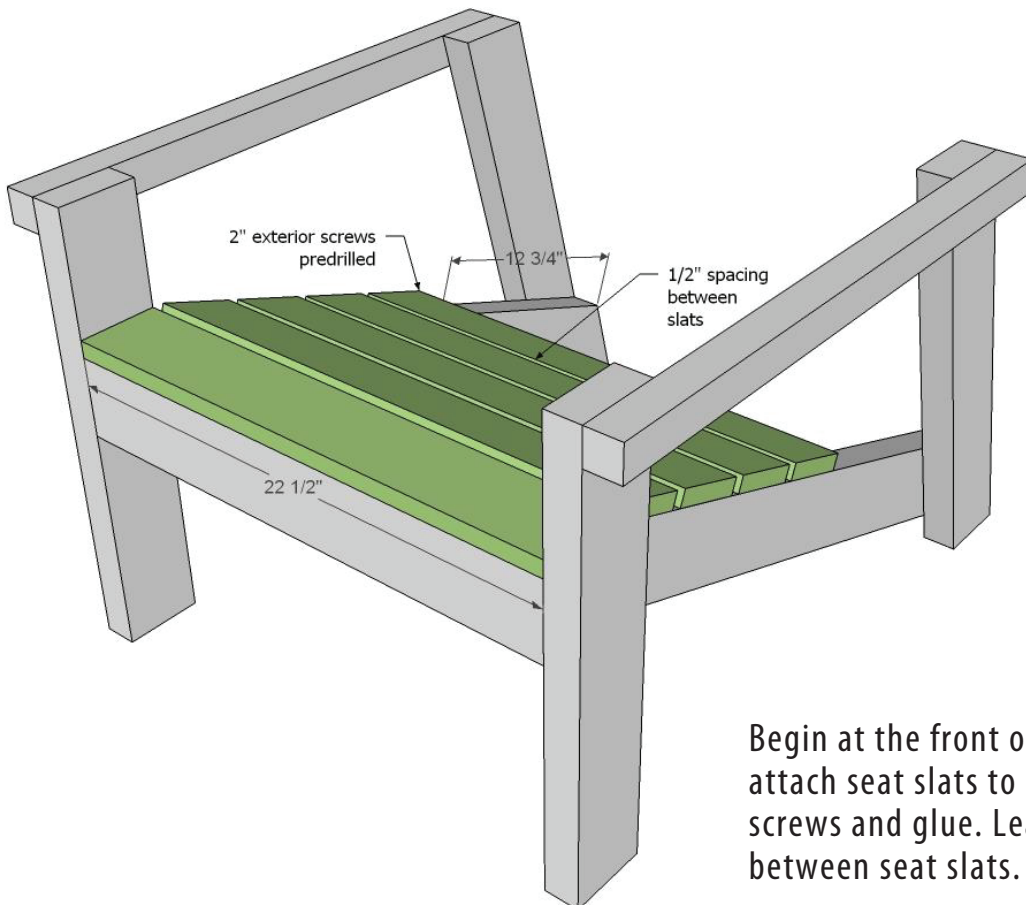

Begin at the front of the chair and attach seat slats to stretcher with 2" screws and glue. Leave a 1/2" gap between seat slats.

## STEP 7

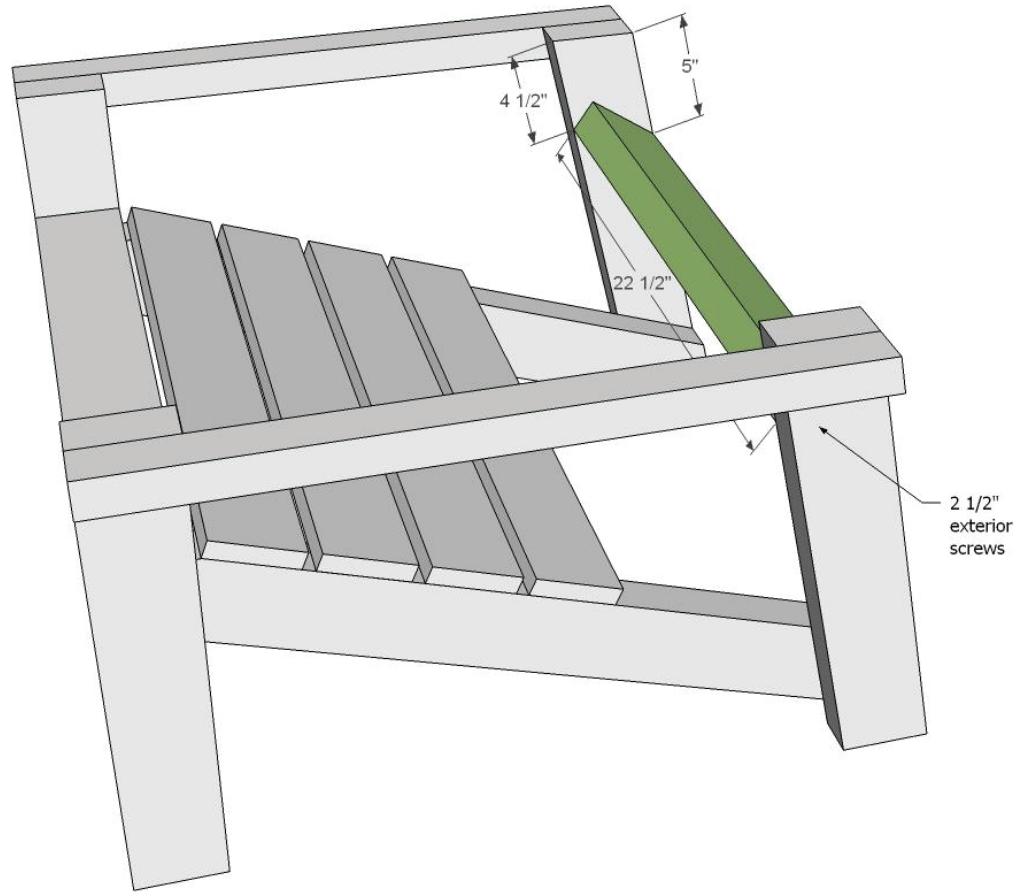

Attach back support to back legs with 2 1/2" exterior screws, matching up measurements in diagrams.

## STEP 8

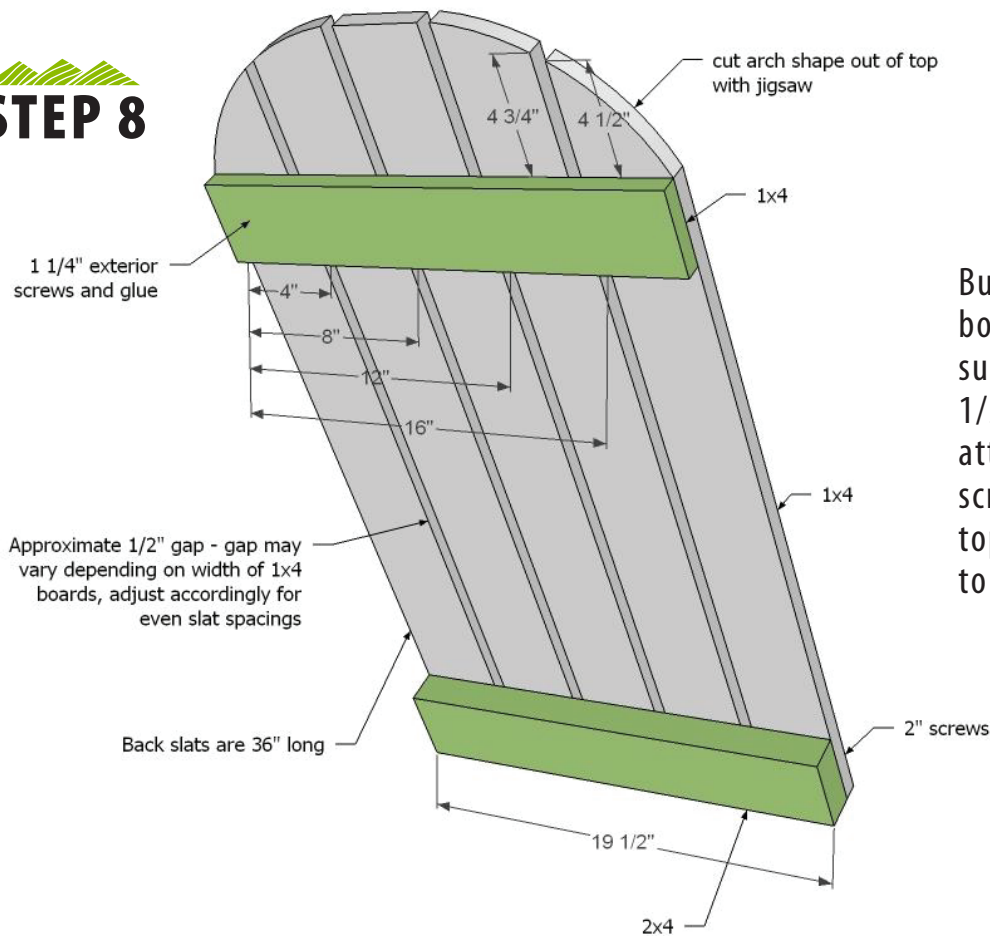

Build back by attaching all back boards to seat back base support, leaving approximately 1/2" gap in between. Then attach at top with 1 1/4" screws. Cut arch shape on back top using a large round object to guide you.

## STEP 9

Place back inside chair and secure in place with 2 1/2" exterior screws. Also screw back to back support with 2" exterior screws.

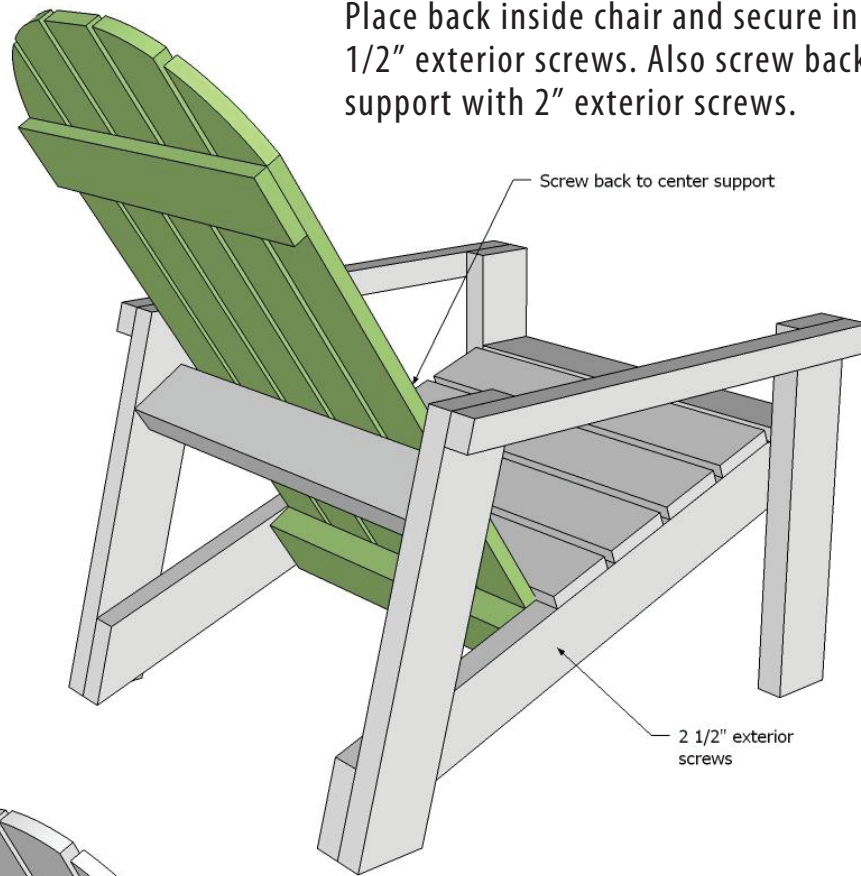

## STEP 10

Secure armrests to arm supports and tops of legs with screws and glue.

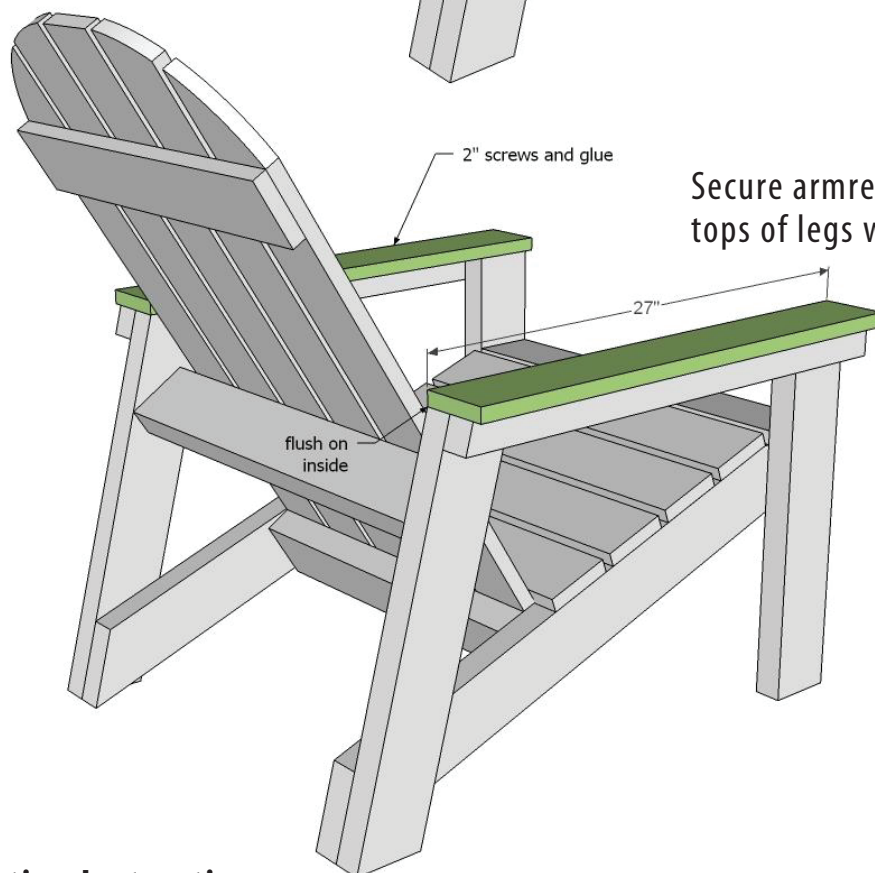

### Finishing/Preparation Instructions

Fill all holes with wood filler and let dry. Apply additional coats of wood filler as needed. When wood filler is completely dry, sand the project in the direction of the wood grain with 120 grit sandpaper. Vacuum sanded project to remove sanding residue. Remove all sanding residue on work surfaces as well. Wipe project clean with damp cloth.

It is always recommended to apply a test coat on a hidden area or scrap piece to ensure color evenness and adhesion. Use primer or wood conditioner as needed.