

# Fence Picket Planter

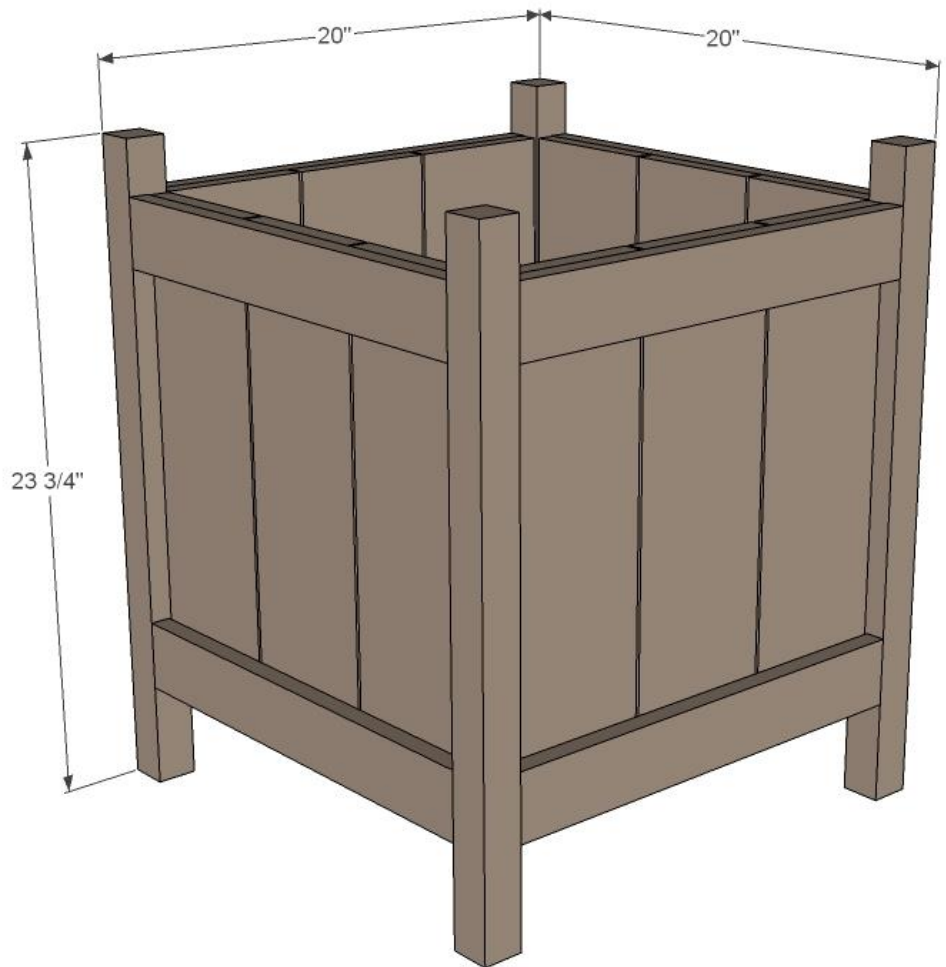

## SHOPPING LIST

- 2 - Culpeper 1x3 @ 8 feet long
- 1 - Culpeper 1x2 @ 8 feet long
- 3 - Culpeper 5 1/2" wide x 72" long cedar fence pickets
- 1 - Culpeper Ground Contact 2x2 @ 8 feet long
- 2 1/2" exterior pocket hole screws
- 1 1/4" exterior screws or galvanized nails
- Exterior wood glue



## CUT LIST

- 10 - 1x3 @ 17"
- 5 - 1x2 @ 17"
- 4 - 2x2 @ 23 3/4"
- 12 - cedar fence pickets @ 17 3/4" long  
(shortened by 1/4" from diagrams to allow for saw blade width and dog-eared end)

# STEP 1

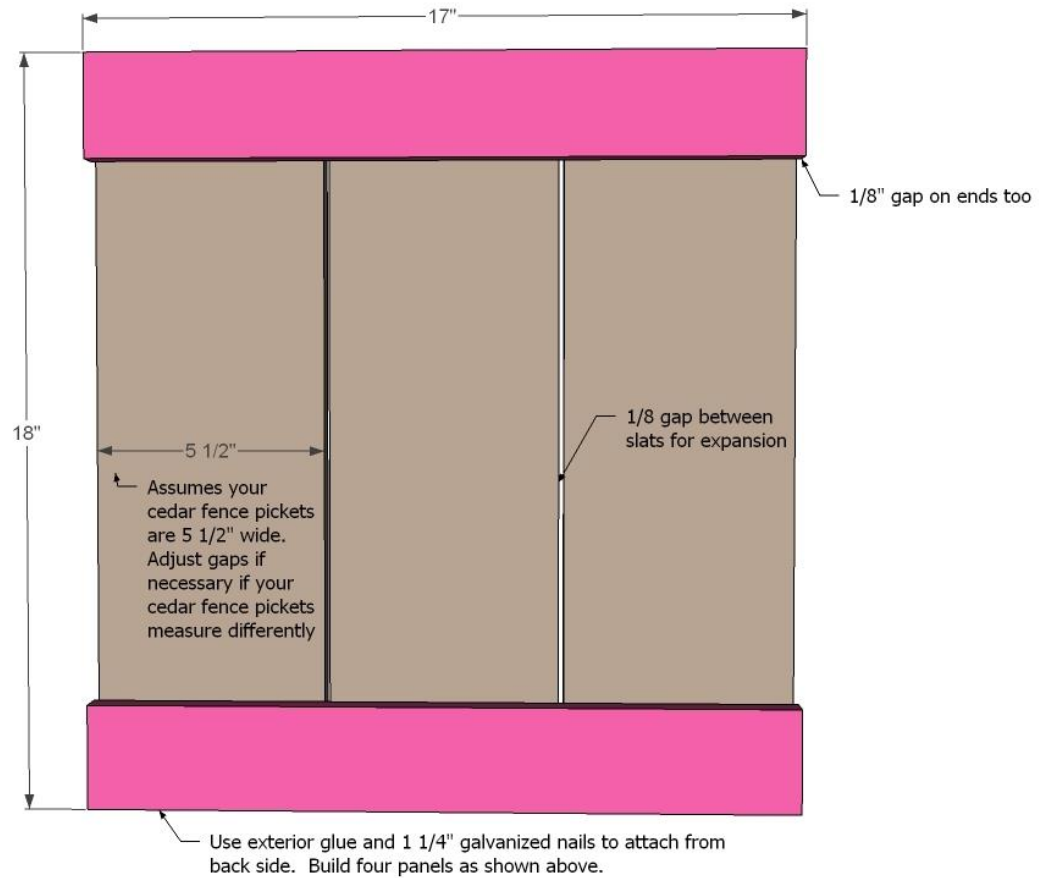

Start by building the four panels. This plan allows for a 1/8" gap between the cedar pickets as they will shrink/expand with moisture, and taking into account board imperfections. Use 1 1/4" galvanized nails and exterior glue from the insides.

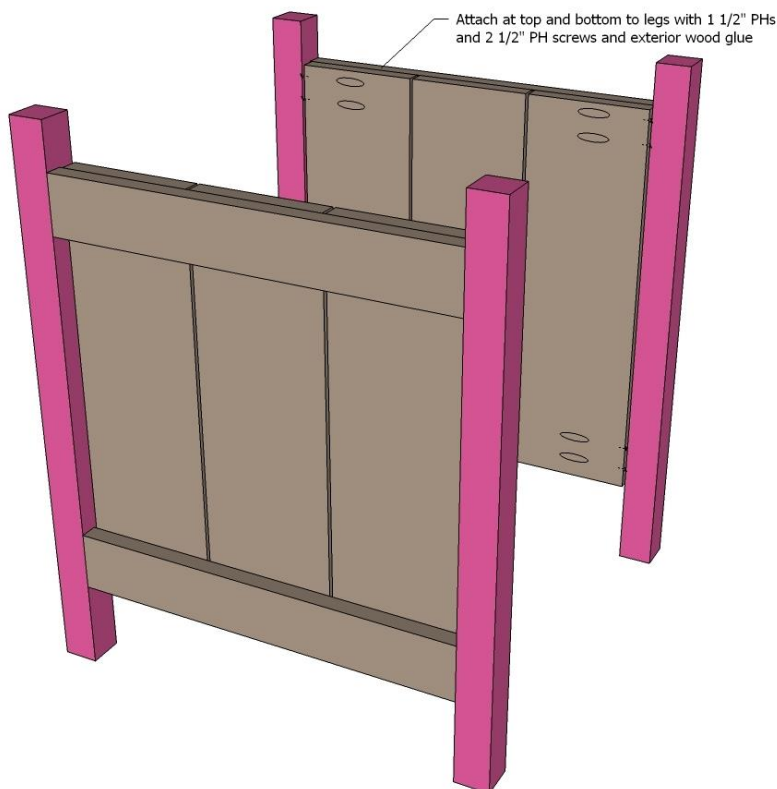

# STEP 2

On all four of your panels, drill 2 - 1 1/2" pocket holes on the inside, behind each 1x3 on the ends. This will put screws through the fence pickets, 1x3s and then into the legs. Join two of the panels to the legs as shown in diagram.

# STEP 3

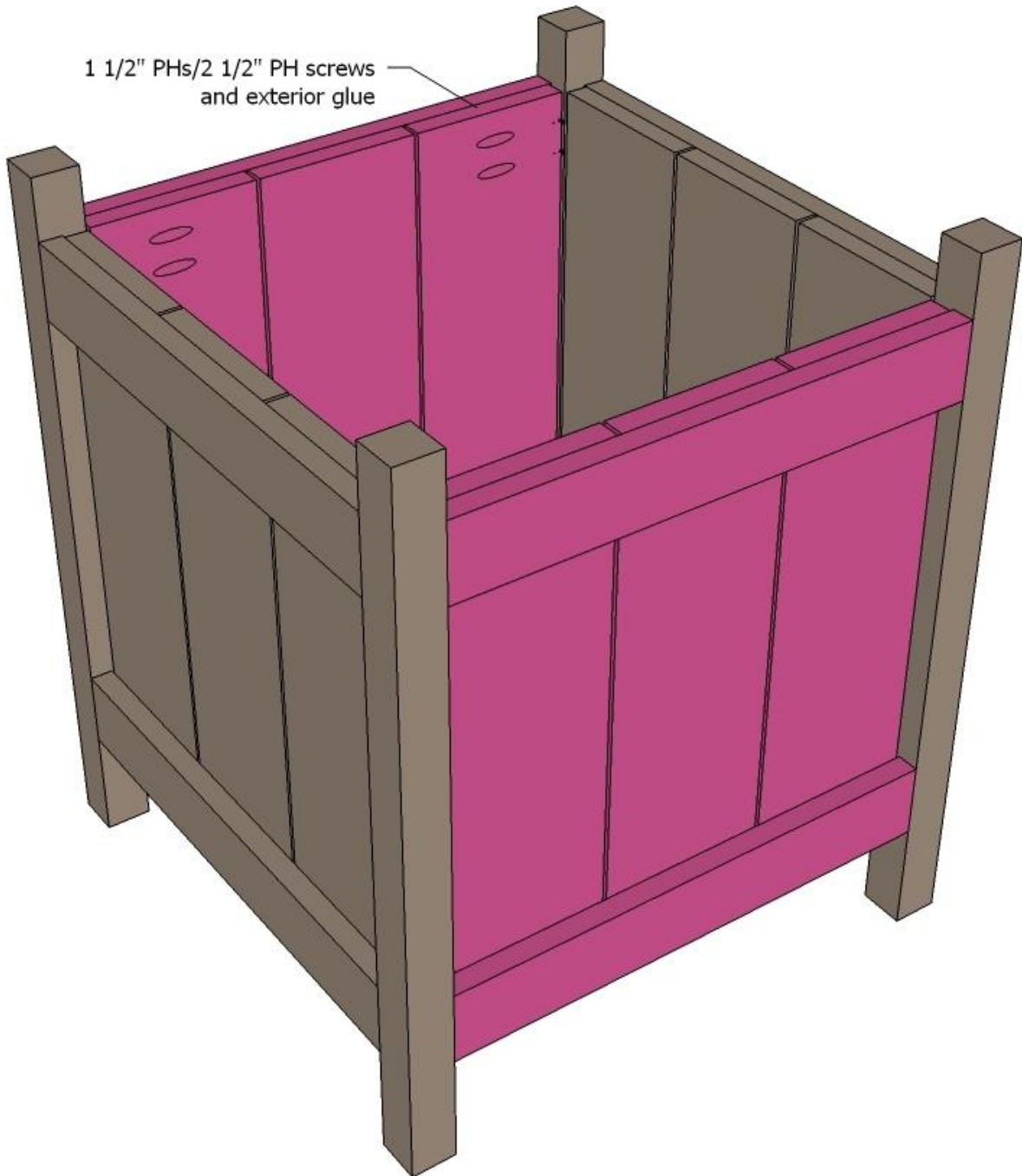

Add the remaining two panels to create your planters. Adjust for square.

## STEP 4

NOTE: The whole planter does not need to be filled with dirt.

The bottom can be positioned anywhere - shown here 6" down from the top to keep the planter lighter and use less dirt.

Start by attaching cleats to sides at desired height.

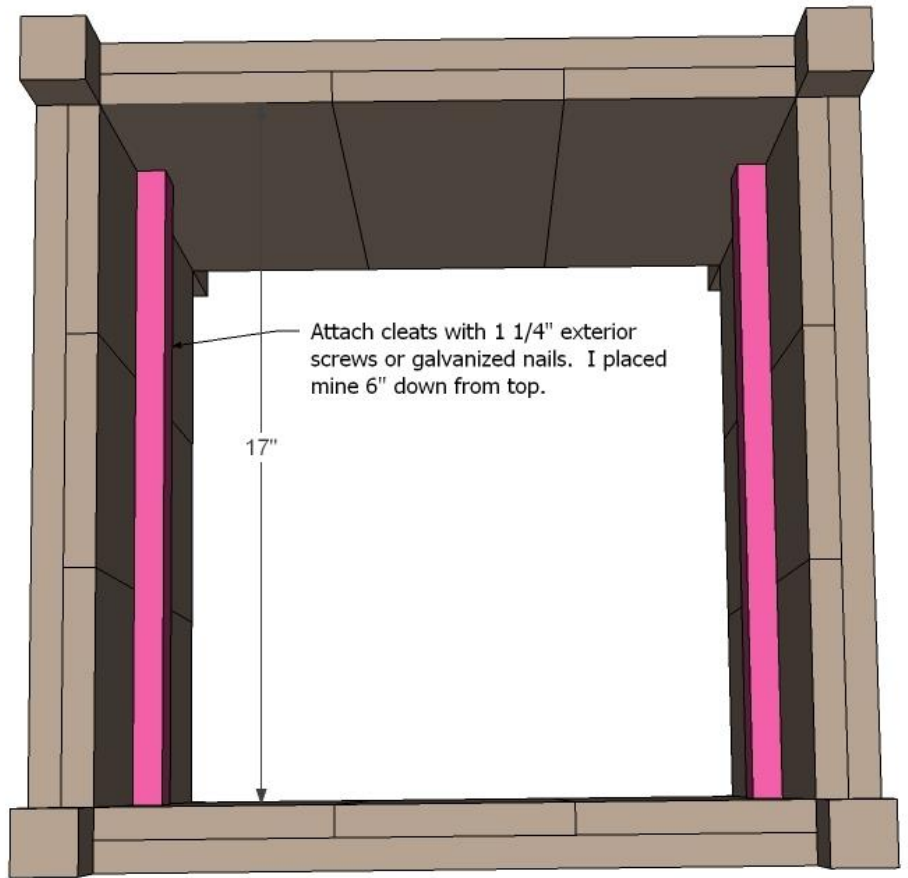

## STEP 5

Lay what boards you have leftover down as slats to hold the planter container or cover with gardener's cloth and fill with topsoil and plants.

