

Picnic Table

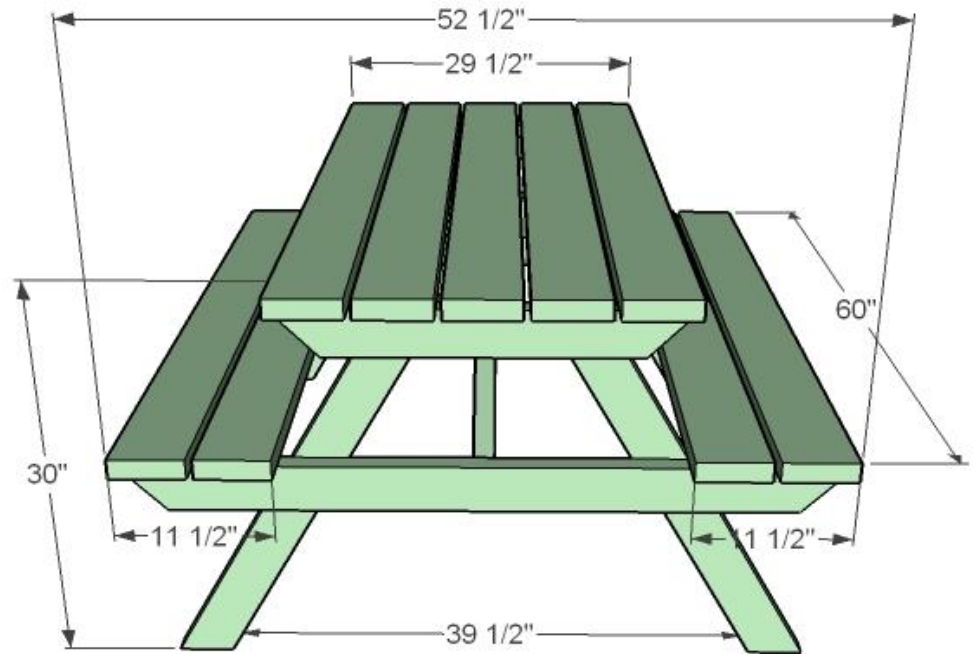

Shopping list

- 9 – Culpeper Ground Contact 2×6 Stud Length OR 4 – 2×6 12' Long and 1 – 2×6 Stud Length (8' Length works if it is cheaper)
- 5 – Culpeper Ground Contact 2×4 Boards, 8' or Stud Length
- 2 ½" self-tapping deck screws
- OPTIONAL: You can bolt the leg sets together with 3 ½" bolts with nuts and washers. Make sure all fasteners are exterior appropriate.



Common Materials

- 2 ½-inch screws
- 3-inch screws
- 1 ¼" Pocket Hole Screws
- 2 ½" Pocket Hole Screws
- Wood Glue
- Wood Filler

Cut List

- 9 – 2×6 @ 60" (Tabletop boards and Seat Boards)
- 3 – 2×4 @ 29 ½" (Tabletop Supports)
- 4 – 2×4 @ 33" (Ends mitered at 30 degrees parallel)
- 2 – 2×4 @ 52 ½" (Seat Supports)
- 2 – 2×4 @ 28 ½" (Cross Supports, ends mitered at 25 degrees parallel)

STEP 1

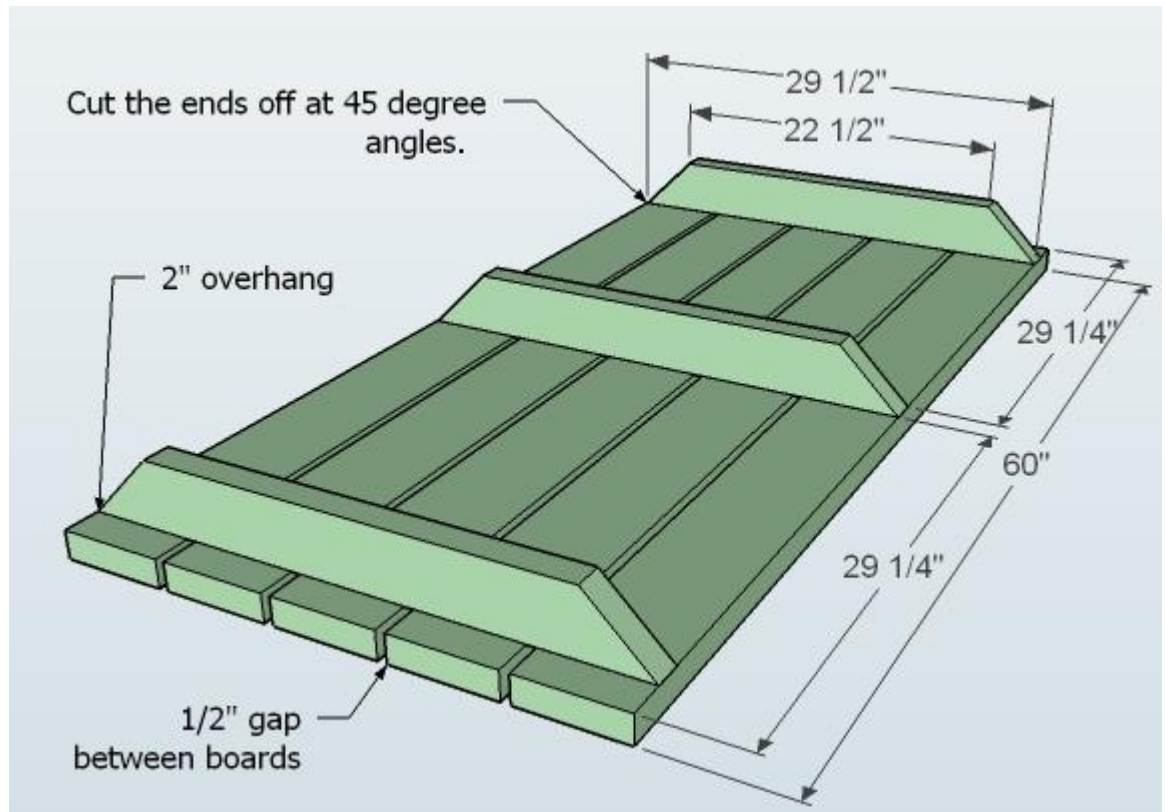

Measure 2" and 29 1/4" from the outsides of all the tabletop boards and make a mark.

Cut support board ends at a 45-degree angle on the ends as shown above.

Attach the tabletop boards to the supports through the tops using 2 1/2" screws and glue. Start on the outsides and work inward, keeping an even 1/2" gap between the boards. Use the marks made to guide you in placing the support boards in line with the tabletop boards.

NOTE: Pocket hole users can attach from underneath with pocket holes to hide all screw holes.

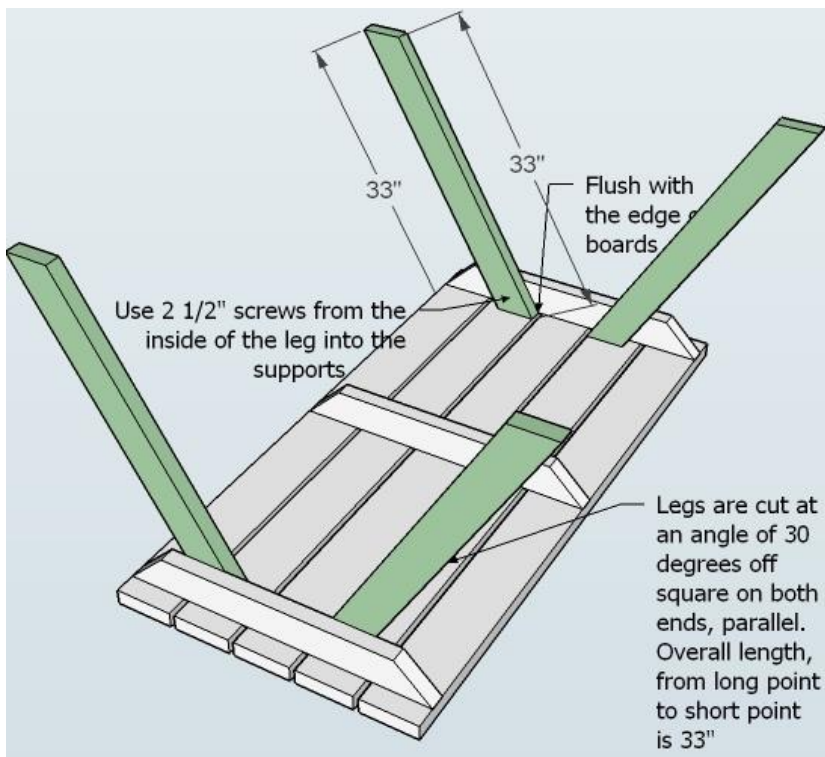

STEP 2

Cut legs at 30-degree angles on both ends, so the ends are parallel.

Line up the legs with the inner edge of the boards between the middle and outside boards.

Use 2 1/2" screws and glue to fasten to the inside of the table support as shown.

STEP 3

Ends are mitered down at 45 degree angles.

Use a square to measure at a 90 degree angle from the underside of the table top up 12" on the legs as shown here. Mark the legs here.

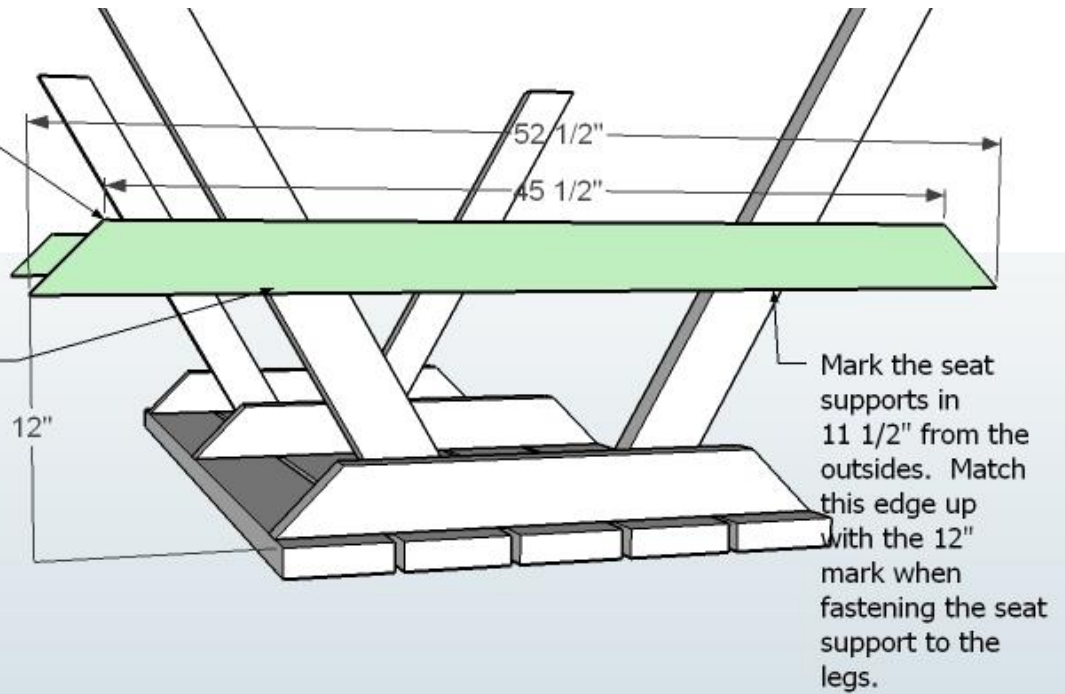

Take square and measure at a 90-degree angle from the underside of the table up 12" and make a mark on the legs. Cut seat supports at 45-degree angles on the ends.

From the long point, measure 11 1/2" from the outer point and make a mark. Line this mark up with the edge of the legs, keeping the top of the seat support (shown as the bottom because the table is upside down) level with the marks made on the legs. Fasten with 2 1/2" screws and glue.

STEP 4

Cross bracing is 2x4s cut with ends at 25 degrees off square. The length is from short point to long point.

Screw to the seat supports

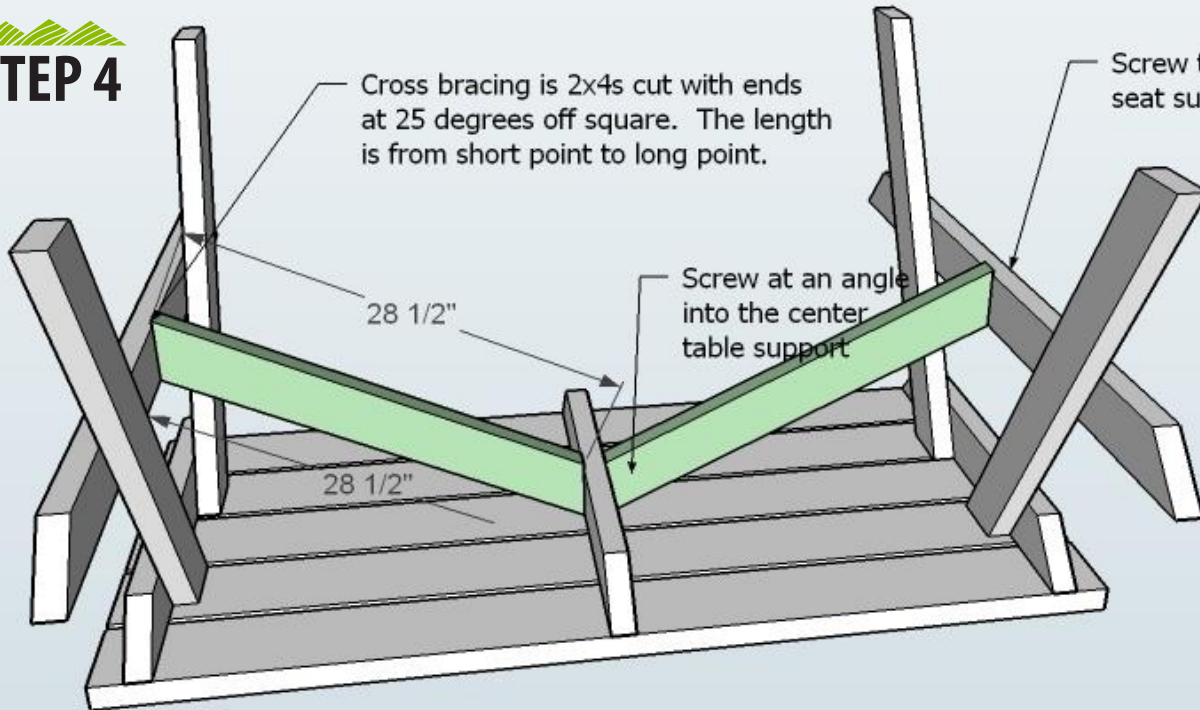

Take a square of the table by measuring from the outer points of the legs to the diagonal opposite leg. Do this for both diagonals. Push the opposite legs together on the longer diagonal until your diagonals match up in distance. Cut cross supports at 25 degrees off square on both ends, (ends are parallel).

Fasten in place using 2 1/2" screws and glue, centered on the supports as shown. For one of the cross supports, screw at an angle from the side of the cross support in the tabletop support.

STEP 5

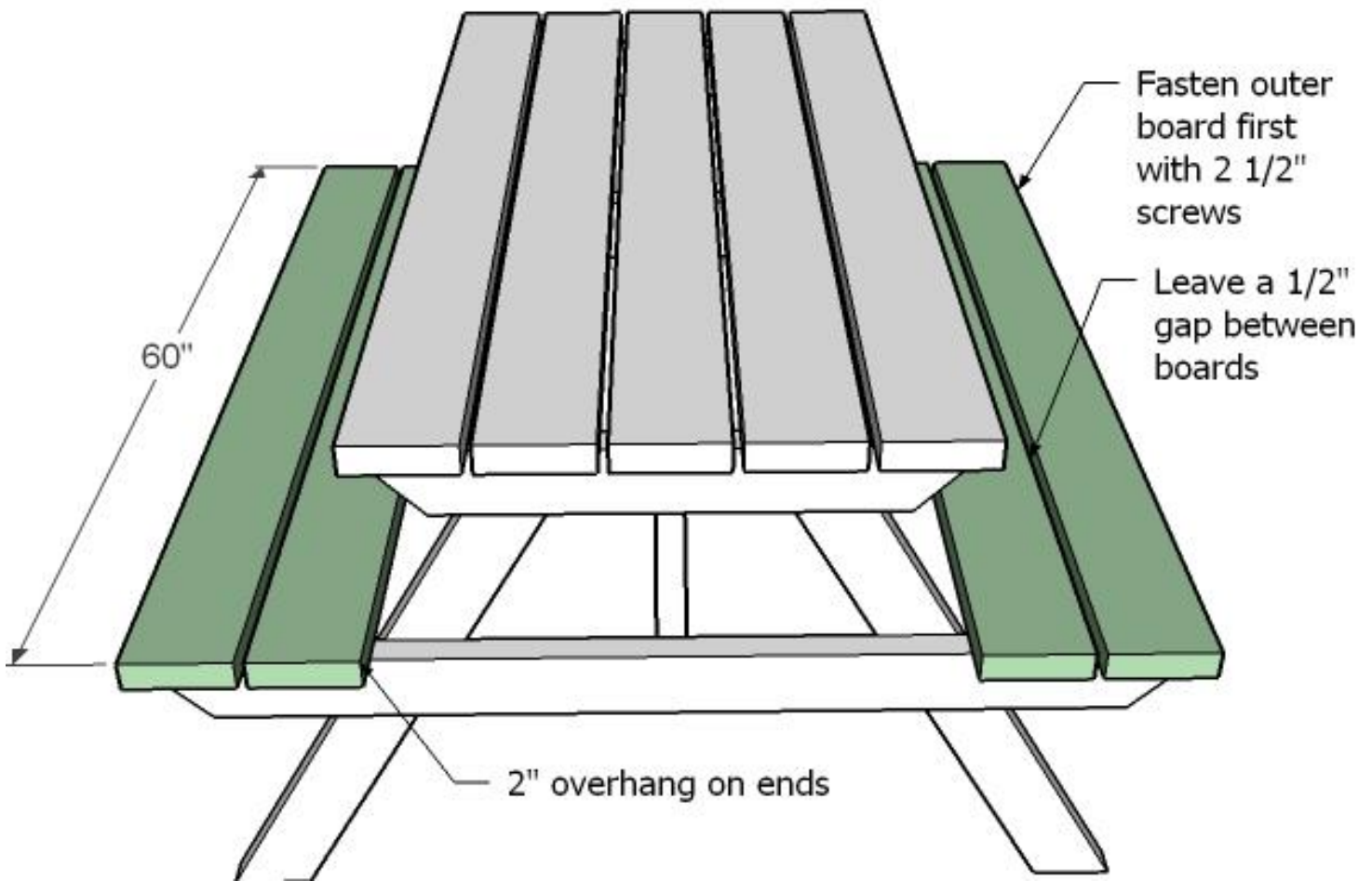

Attach the seat boards to the picnic table with screws to complete.

Finishing Instructions

Fill all holes with wood filler and let dry. Apply additional coats of wood filler as needed.

When wood filler is completely dry, sand the project in the direction of the wood grain with 120 grit sandpaper. Vacuum sanded project and work station to remove sanding residue. Wipe project clean with damp cloth.

Finish with paint, stain, polyurethane or other method you prefer.