

# Porch Swing

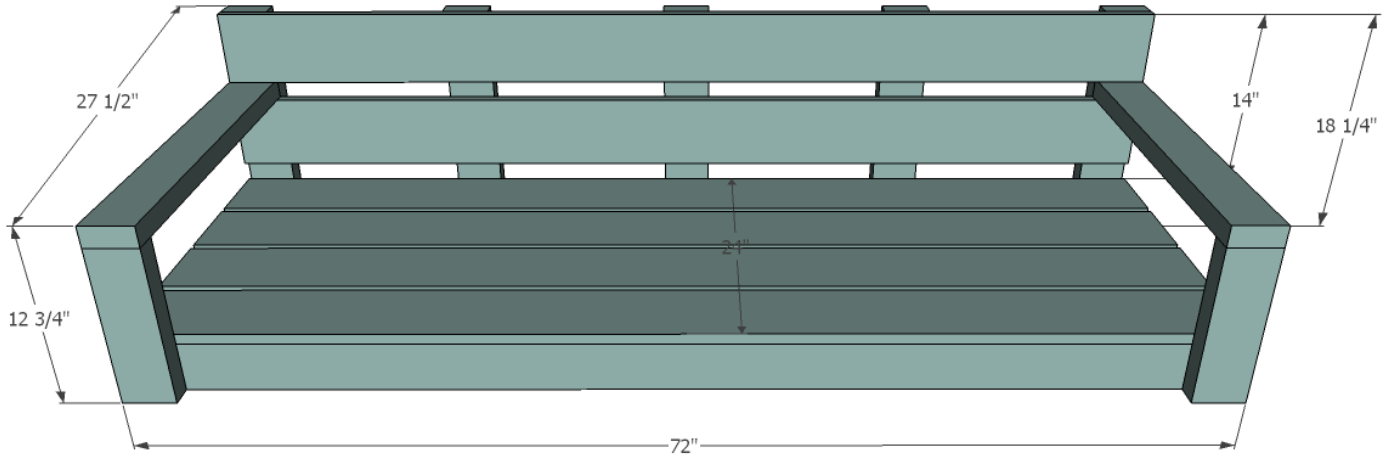

## Shopping list

- 6 - Culpeper 1x6 @ 6 feet long
- 5 - Culpeper 2x4 @ 8 feet long
- 4 - Eye Bolts with Nuts, 3" long
- Chains or rope, (shown using 200 pound weight limit for four ropes, capacity of 800 pounds)
- Hardware to hang to rafters/tree

## Common Materials

- 2 1/2-inch screws
- 2-inch finish nails
- 2 1/2" Pocket Hole Screws
- Wood Glue
- Wood Filler

## Cut List

- 5 - 2x4 @ 21" (Support Joists)
- 2 - 2x4 @ 72" (Front/Back Aprons)
- 2 - 2x4 @ 11 1/4" (Arm Fronts)
- 2 - 2x4 @ 25 1/2" (Arm Rests)
- 5 - 2x4 @ 18 1/4" (Back Supports)
- 6 - 1x6 @ 72" (slats)

## General Instructions

- Take every precaution to build safely and smartly.
- Work on a clean level surface, free of imperfections or debris.
- Always use straight boards.
- Check for square after each step.
- Always predrill holes before attaching with screws.
- Use glue with finish nails for a stronger hold.
- Wipe excess glue off bare wood for stained projects, as dried glue will not take stain.

## STEP 1

Build the seat frame as shown above, using either pocket holes set for 1 1/2" stock and 2 1/2" screws, or wood glue and 2 1/2" screws predrilled and countersunk.

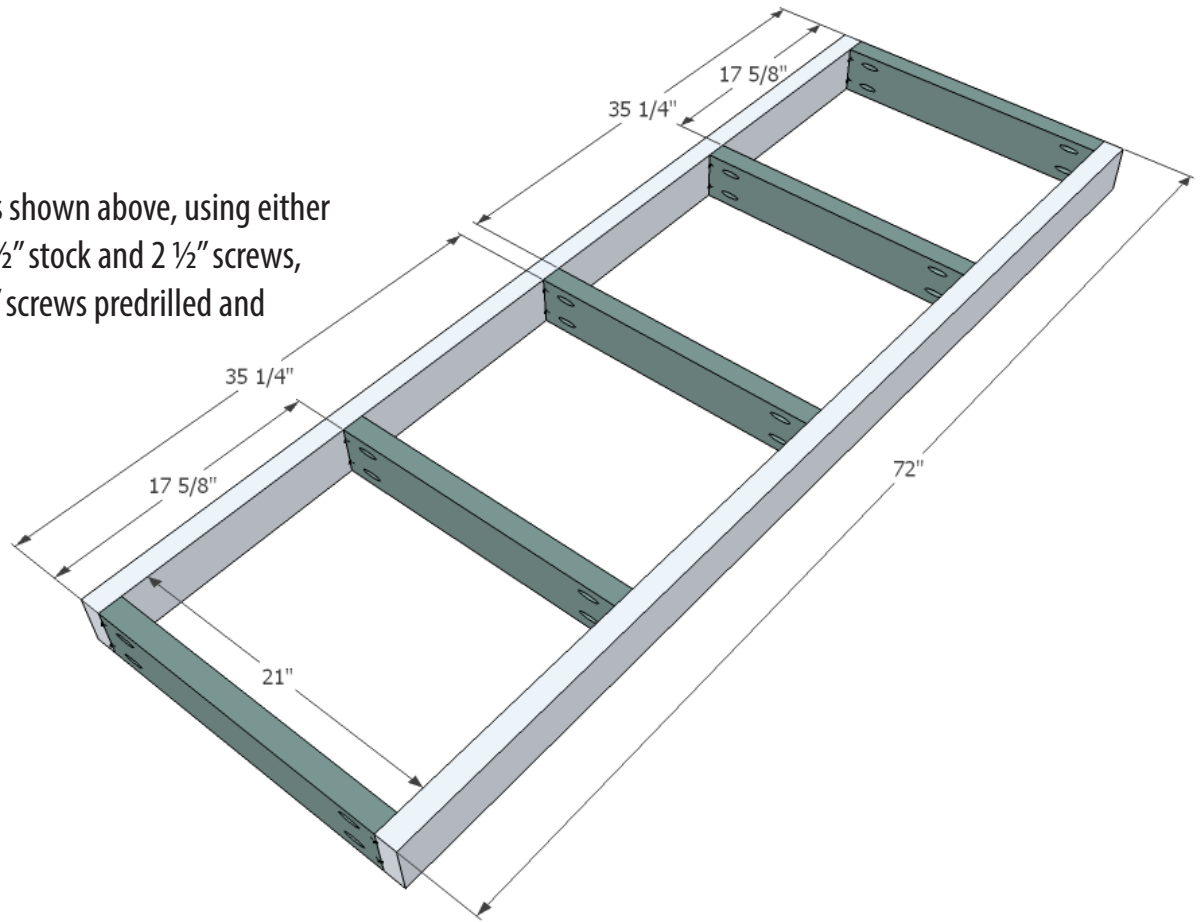

## STEP 2

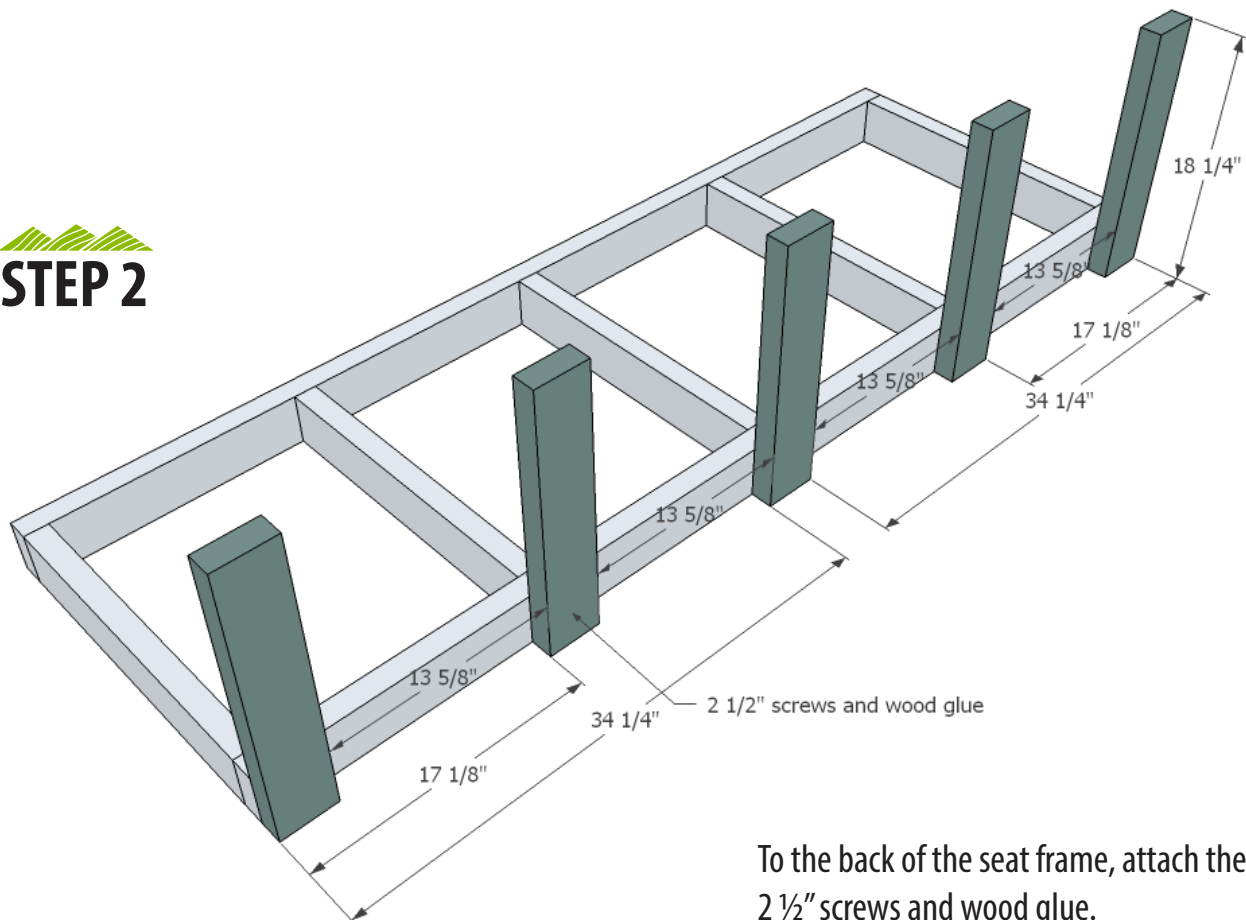

To the back of the seat frame, attach the back supports, 2 1/2" screws and wood glue.

### STEP 3

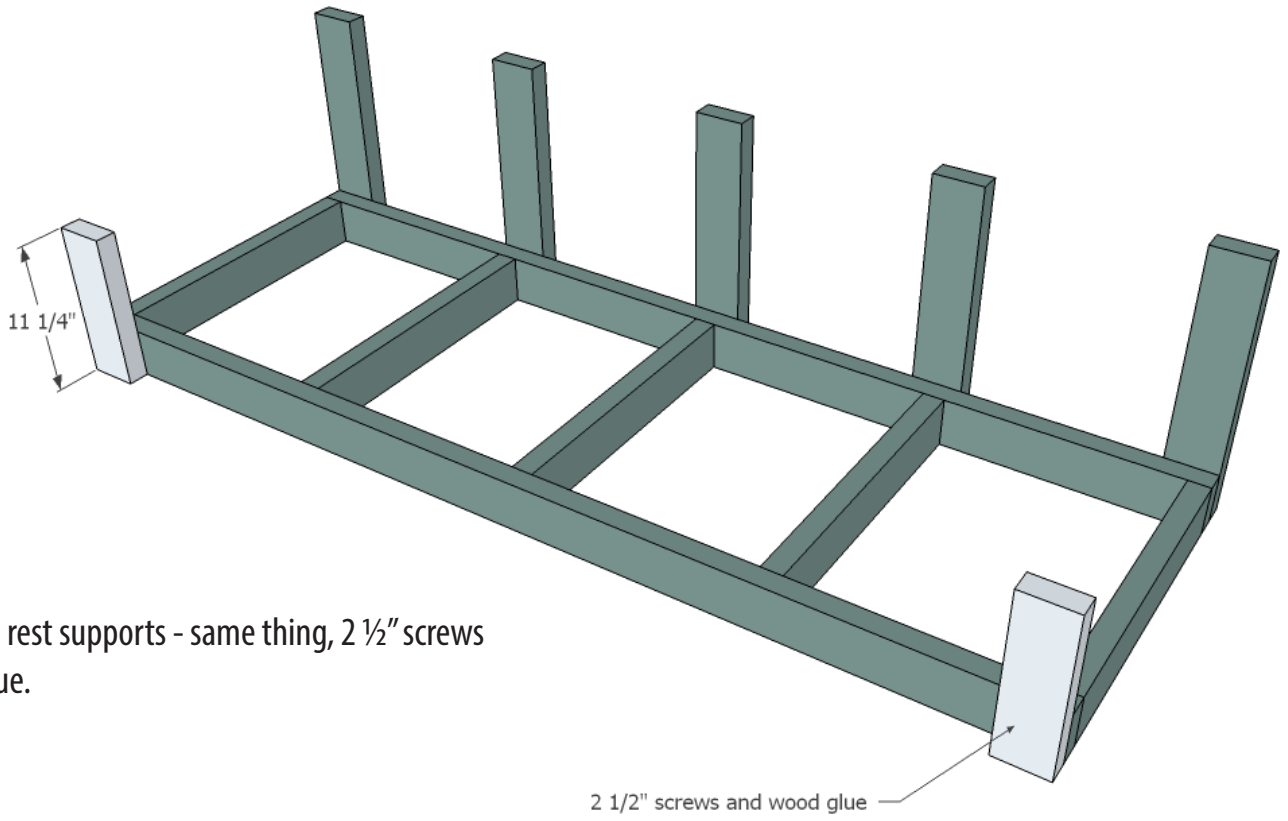

Now the arm rest supports - same thing, 2 1/2" screws and wood glue.

### STEP 4

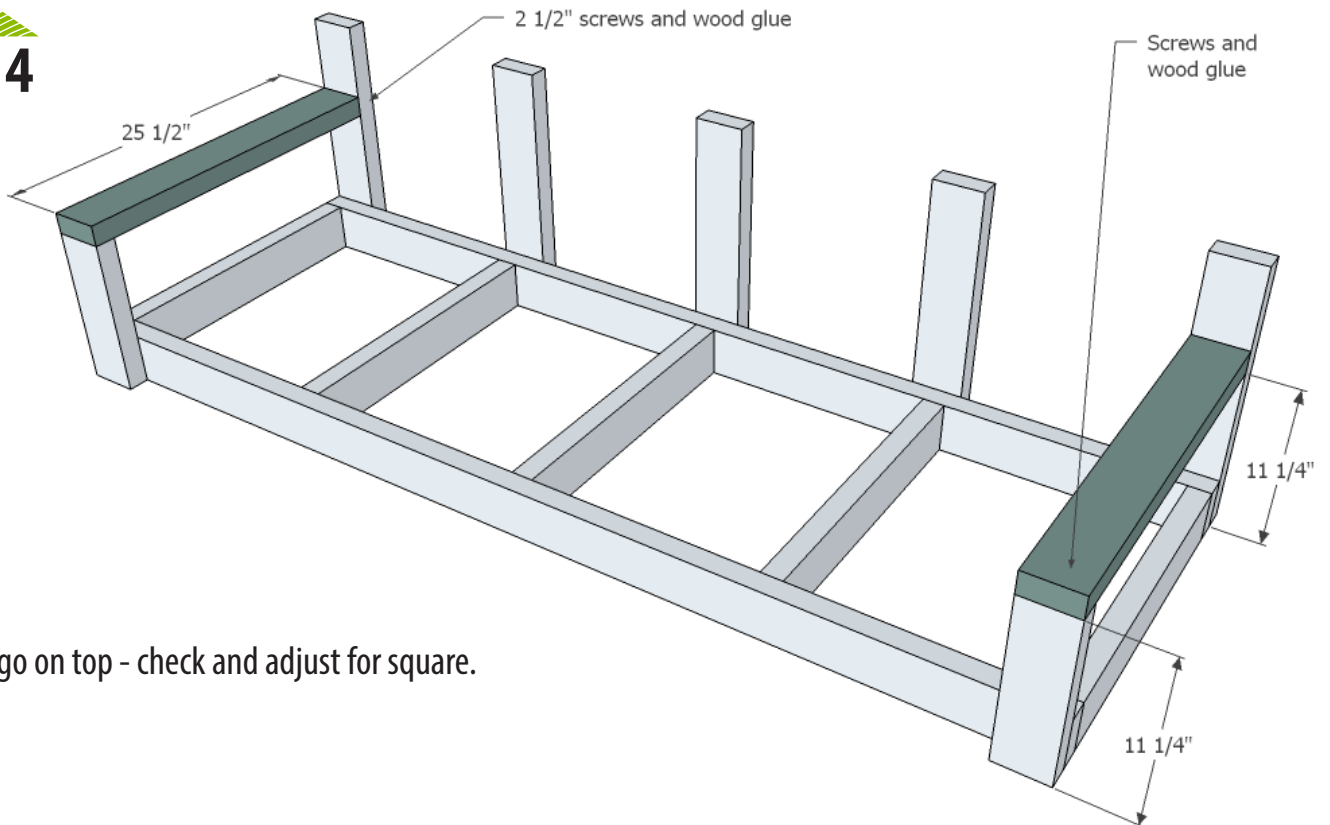

Armrests go on top - check and adjust for square.

## STEP 5

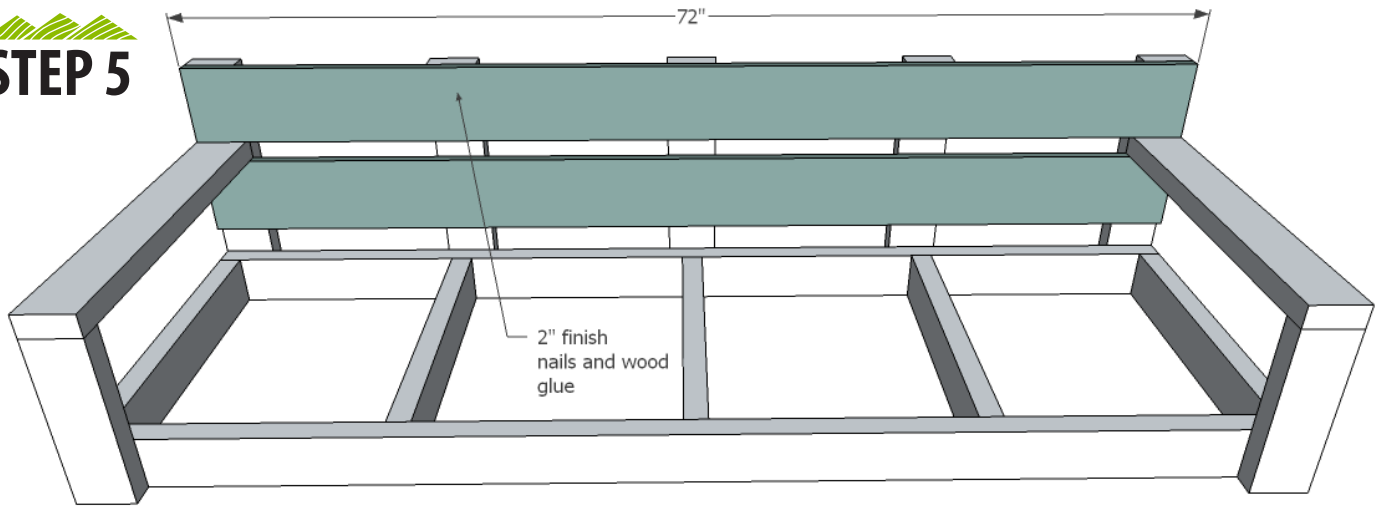

## STEP 6

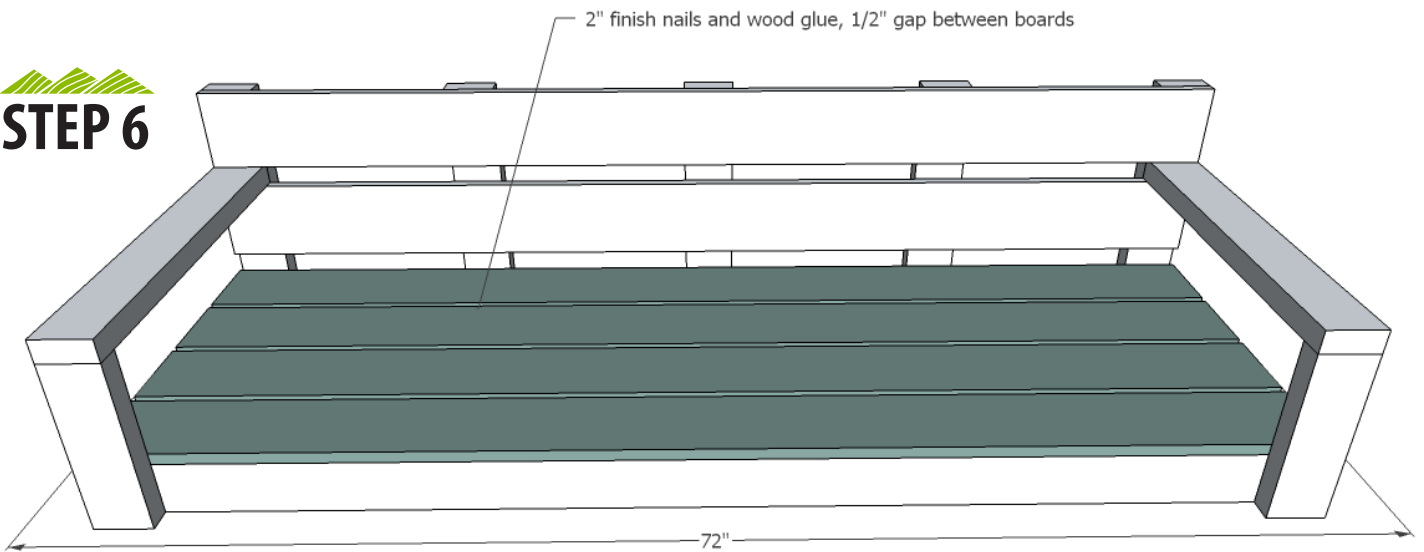

And finally, the seat slats - start at the front, leave  $\frac{1}{2}$ " gaps, and nail and glue down with 2" finish nails.

### Finishing Instructions

Fill all holes with wood filler and let dry. Apply additional coats of wood filler as needed.

When wood filler is completely dry, sand the project in the direction of the wood grain with 120 grit sandpaper. Vacuum sanded project and work station to remove sanding residue. Wipe project clean with damp cloth.

Finish with paint, stain, polyurethane or other method you prefer.

Hang swing from the side aprons of the seat frame - that is where most of your weight will be.

**DISCLAIMER:** Build, hang and use at your own risk - not liable for personal injury, loss or death from use of swing.